

# Saf-T CI Vent®

*Commercial & Industrial  
Positive Pressure or Condensing  
AL 29-4C® Stainless Steel  
High Challenge Special Gas Vent  
Also for Natural Draft Appliances  
3", 4", 5", 6", 7", 8", 9", 10" and 12" Diameter  
Special Gas Vent Connector  
14", 16", and 18" Diameter*

## *Installation and Maintenance Instructions*



The Saf-T Vent Special Gas Vent System may be used to vent an appliance with a UL<sup>®</sup> Temperature Rating of less than 550° F including Category III and IV gas appliances marked or labeled by Underwriters Laboratories, American Gas Association Labs, or other recognized agency. The connected appliance must be Listed for use with a Type B Vent or an AL 29-4C<sup>®</sup> vent system. This Saf-T Vent system may be connected to appliances with positive vent pressures of 3.0 inches of water column or less, but because these types of appliances may produce vent gases under positive pressure and/or at or near their dew point, special installation considerations are required. Read and follow these instructions completely, together with the appliance manufacturer's instructions and any applicable local, state and national codes. Read and understand all parts of this manual before beginning any installation.

Consult the appliance manufacturer's instructions for the maximum horizontal length of the vent connector, as well as any restriction on total vent height, proper sizing of the vent, common venting considerations and procedure for connecting the vent to the appliance.

**PRE-INSTALLATION CONSIDERATION**

This Special Gas Vent System may be installed in four separate orientations depending on the requirements of the building and the appliance. The installer must decide which method is most appropriate for each installation. These orientations are: 1. Horizontal vent termination directly through an outside wall (figure 1.). 2. Vertically through un-enclosed or enclosed areas with roof penetration w/ no enclosed offsets (figure 2). 3. Horizontally in a system incorporating enclosed vertical offsets Maximum Temperature Rating of the connected Appliance must be 400° F or less if fully enclosed by combustible materials (figure 3.). 4. As a relining system vertically through a masonry chimney (figure 4.). Be aware that some appliances are Listed for limited horizontal and/or vertical vent lengths as well as vent size. Refer to Appliance Manufacturer's Instructions for these and other possible restrictions.

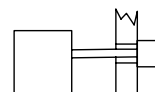

Figure 1.

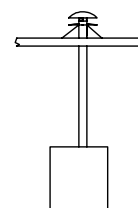

Figure 2.

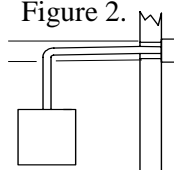

Figure 3.

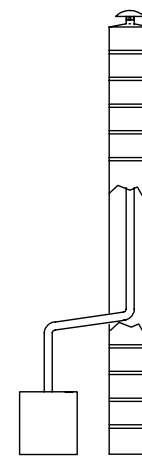

Figure 4.

**GENERAL INSTALLATION REQUIREMENTS**

1. Failure to conform with any of these requirements may violate local, state or national codes as well as create conditions which may cause catastrophic property damage or personal injury.

2. 90°, 45° or other elbows may be used at any offsets or transitions from vertical to horizontal; tees and increasing boot tees may be used only as described below for multiple venting, clean outs or condensate draining as allowed by the appliance manufacturer's instructions.

3. Saf-T Vent or Saf-T CI Vent conduit sections **must** be used for the entire length of the system; alternatives such as galvanized pipe, PVC, non-metallic pipe, pre-fabricated chimney or Type B Vent sections must not be used.

4. The horizontal vent connector must slope **upward** toward the termination at least 1/4 inch per foot and be installed so that all condensate runs back toward the appliance and is not retained in any part of the venting system. **EXCEPTION.** If the system is connected to positive pressure (Category III or IV) appliances only, terminates with a horizontal termination, and has no provision for draining condensate and/or rain water; the vent must pitch **downward** toward the termination, this pitch should also be 1/4 inch per foot.

5. If called for by the appliance manufacturer's instructions, a drain fitting must be located as close as possible to the appliance flue outlet. If the fitting is not supplied with the appliance, install a Saf-T Vent drain fitting according to the instructions in part IV of this manual. Do not install a drain in an appliance not investigated for use with a drain.

6. All joints between sections of the vent connector and the vertical conduit must be sealed with either GE RTV 106 sealant or Dow Corning #736 sealant, using the installation technique described in Part II of this manual.

7. More than one appliance may not be interconnected to any part of the venting system, unless specifically allowed by the appliance manufacturer's instructions. Under **no** circumstances should a natural draft appliance be interconnected with a forced draft appliance. All connected appliances must be all natural draft or all forced draft. When multiple venting forced draft appliances precautions to prevent back flow must be taken.

8. The venting system must be planned so as to avoid possible contact with concealed plumbing or electrical wiring inside walls, floors or ceilings.

9. The venting system must be planned to maintain an airspace of dimension 'A' for the appropriate material. See chart.

Product	Dim 'A'	
	US Installations	Canadian Installations
Saf-T Vent 4-10" dia	2"	6"
Saf-T Vent 12-18" dia	6"	6"
Saf-T CI Vent	4"	4"

Double wall Saf-T CI Vent must be used after penetrating any floors, walls, or ceilings and any penetrations must be properly firestopped. Any insulating material will be removed from any wall, floor, or ceiling cavity for at least 4 inches from the conduit.

10. The vent system in a multi-family structure must be planned to be enclosed when passing through occupied or unoccupied spaces

above the connected appliance. This enclosure is

to be of materials no less fire resistant than surrounding floors and walls. Heat-Fab recommends that the system be enclosed whenever passing through occupied spaces.

**Note A. When utilizing Saf-T CI Vent of larger than 6 inch diameter any enclosure must be of non-combustible materials.**

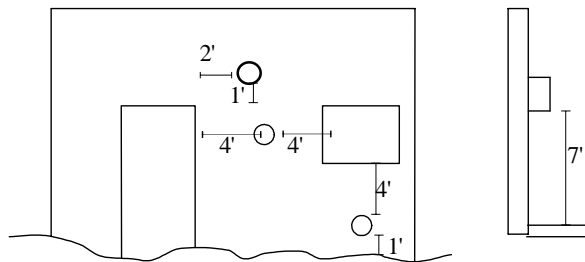
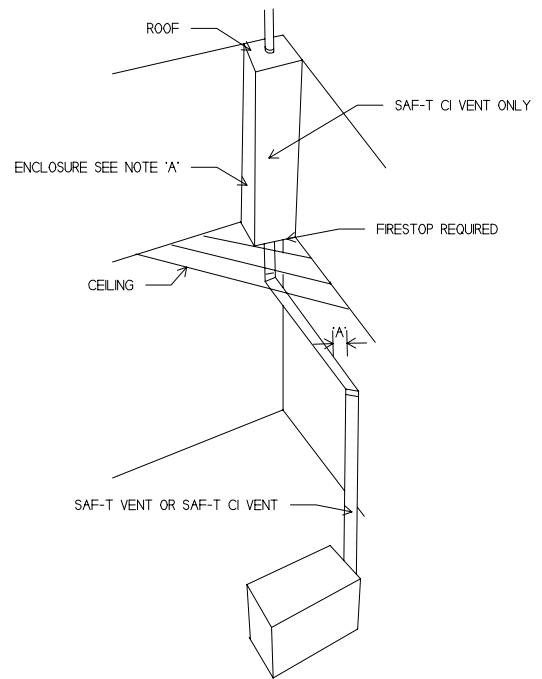

Figure 5.

### **HORIZONTAL INSTALLATION REQUIREMENTS**

1. The vent system must terminate with a Saf-T Vent Through-the-Wall termination. The screen assembly may be replaced with a Saf-T CI Vent Rain Cap if desired.

2. The Through-the-Wall Termination shall be located not less than 12 inches above grade or, in geographical areas where snow accumulates, no less than 12 inches above the anticipated snow line, or not less than 7 feet above grade when located adjacent to a public walkway. It also shall terminate at least 3 feet above any forced air inlet within 10 feet and shall terminate at least 4 feet below, 4 feet horizontally from or 1 foot above AND 2 feet horizontally from any door, window or gravity air inlet into any building as provided in the National Fuel Gas Code NFPA 54 (figure 5). It shall also be at least 8 feet horizontally from any combustion air intake above.

3. The total horizontal distance of the vent system from the appliance flue collar to the outside of the Through-the-Wall Termination shall not be greater than that specified in the appliance manufacturer's installation instructions nor less than 5 feet unless the vent is through a non-combustible wall.

4. Any horizontal system must either pitch downward toward the termination at 1/4 inch per foot or incorporate a drain in the system either integral to the appliance or in the venting system.

5. The system must be Saf-T CI Vent whenever it is totally enclosed or after passing through any interior wall, floor or ceiling. The maximum diameter for a Saf-T CI Vent system enclosed on 4 sides with combustible materials is 6". Larger sizes can be fully enclosed only with non-combustible solid masonry materials.

6. Due to the normal formation of water vapor in the combustion process horizontal terminations must not be located over areas of pedestrian or vehicular traffic. This is especially true in colder climates where ice buildup is likely to occur. Heat-Fab, Inc. will **NOT** be held liable for any personal injury or property damage due to any dislodging of ice.

### **Vertical Installation Requirements**

1. The vent system must terminate at least 3 feet and no more than 6 feet above the roof line, unless it is supported by a wall or similar structure, and no closer than 8 feet from any wall or vertical structure (figure 6).

2. The total continuous vertical distance of the vent system from the appliance flue collar to the rain cap termination shall not exceed that specified in the appliance manufacturer's installation instructions (see Vertical Support and Roof Jack Instructions for minimum support spacing). When venting natural draft appliances the termination must be at least 5 feet above the topmost draft hood or a Listed mechanical draft inducing device is required.

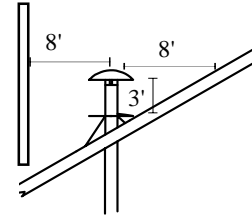

Figure 6

3. A Saf-T CI Vent Rain Cap must be used at the termination for all Category I or II appliances. The rain cap may be omitted on positive pressure appliances provided there are other provisions for draining rain water from the system. A Screen Kit may be installed if required by local or regional codes.

4. In general, systems installed in cold climates perform best and condensation is reduced when the system is fully enclosed.

5. All conduit must be of double wall Saf-T CI Vent after passing through any wall, floor, ceiling or roof. Saf-T Vent single wall conduit may not be fully enclosed, except when used to reline a masonry chimney see **Masonry Chimney Relining** below.

### **INSTALLATION CONSIDERATIONS**

Proper operation of the appliance and venting system is dependent upon use of all specified parts and installation techniques; both safety and proper performance of the system may suffer if instructions are not followed.

### **INSTALLATION PROCEDURE**

#### **Personal Safety**

Wear eye protection and heavy gloves throughout the installation. Use caution when working on roofs and/or scaffolding. Proper and safe scaffolding and/or ladders should be used. All ladders should be secured when in use. Check overhead for antennas, power lines or other obstacles before erecting ladders or scaffolding and while working with conduit on any roof structure.

Clear a safe working area around the appliance to be connected as well as around any areas which will be passed through by the venting system. If necessary lay down drop cloths to protect floors and furnishings.

#### **Tools Needed**

Measuring Tape	Pliers	Hammer	Screw Driver
Circular Saw	Saws-All	Electric Drill	Hole Saw
Framing Square	Level	Gloves	Eye Protection
Drop Cloth(s)	Duct Tape	Caulking	Ladder/Scaffold

Other tools may be required for specific installations.

### **GENERAL INSTALLATION PROCEDURE**

Prior to beginning the installation of a Saf-T Vent Special Gas Vent System assemble all parts required for the installation. Refer to part II of this manual for specific parts needed for each installation.

Prepare the route for the conduit; open and securely frame around the required penetrations of walls, floors, ceilings or roof, leaving the required air space clearance of 4 inches. Remove any insulation or other combustible materials from this clearance. Use framing members the same dimension as those already in the structure (see part II of this manual). The framed in openings will be 8 inches larger (minimum) than the nominal diameter of the Saf-T CI Vent Conduit being used. If the penetrations are through floors or ceilings install the required firestops to the top of framing members.

Pre-assemble loosely the sections of Saf-T Vent or Saf-T CI Vent to assure that the system is aligned correctly with the openings, and that all required parts are on hand.

## PART II

### **DETAILED THROUGH-THE-WALL INSTALLATION**

Determine a safe and proper location for the Through-the-Wall termination using the guidelines provided in the Pre-Installation Considerations above. It will be helpful to drill a small 1/4 inch locator hole through the wall to verify the position inside and outside. Make sure any electrical wiring or plumbing is not located in the area you will be opening. Once a safe and proper location has been chosen enlarge the locator hole using a Saws-All or Hole Saw to 5 inches larger than the Saf-T Vent being installed.

Position the Through-the-Wall termination assembly into the enlarged hole from the outside. Secure the assembly to the exterior sheathing using hollow wall anchors or wood screws as indicated by the sheathing. Seal under the screw heads with caulking. (Use 4 hollow wall anchors, at least 1/4 inch in diameter and of an appropriate length for the thickness of the sheathing, for particleboard or other composite material. Use 4 #10 x 1.25" wood screws for plywood or wood sheathing or when passing through solid wood members. Use suitable masonry anchors when passing through solid masonry walls.) See Detailed Instructions packed with the Wall Penetration Assembly.

Reinstall the sheathing around the Through-the-Wall termination assembly. This assembly may be painted to match the exterior decor.

Beginning with the appliance flue collar connect appropriate sections of Saf-T Vent or Saf-T CI Vent as described below maintaining a continuous pitch of at least 1/4 inch per foot, continuing to a point at least 2" beyond the thimble portion of the wall termination. A mitre cut may be made provided the minimum length beyond the thimble is 2". If the horizontal portion of the vent connector is longer than 6 feet, install hanger straps (fabricated from non-combustible material) every 6 feet to support the connector from ceiling joists or other solid structures.

**Note:Do not** rivet or screw the straps to the conduit or otherwise puncture the conduit wall. Instead, wrap an extra loop of strap around the conduit to hold it in position. When using Saf-T CI Vent double wall conduit sections the center screw of the coupler may be used to attach support straps.

Before joining the elbow and/or conduit sections together, wipe the male and female ends clean with alcohol wipes. Apply a bead of GERTV 106 sealant, about 1/4 inch in diameter, completely around the *male* (without the tabs) end of each conduit section or elbow, between 1/4 and 3/8 inch from the end of the section. Also run a similar sized bead down the seam weld of each section, from the edge of the pipe to the top of the bulge (figure 7).

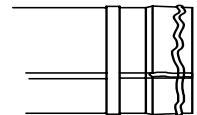

Figure 7.

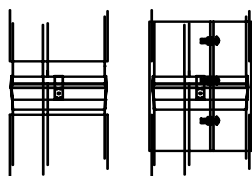
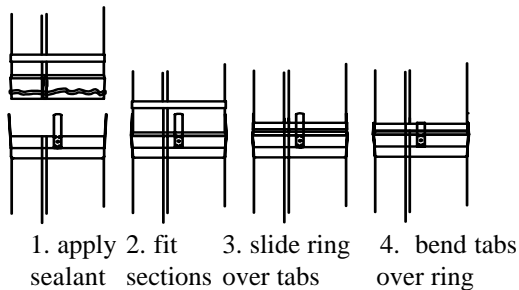

Figure 8.

Fully insert the male end of the section into the female fitting of the section below. With a moistened finger or flat tool, spread any sealant that squeezes out around the circumference of the joint. Attach the sections together with the locking ring and tabs (figure 8 top or for large diameters see part V below). Again spread any extruded sealant around the joint. Finally, inspect the joint to ensure that flue gases will not escape. If necessary, apply additional sealant to any visible voids around the joint and smooth it into any crevices (pay special attention to any places that may have been damaged in shipping and handling). **Allow the sealant to cure for 24 hours before operating the appliance.**

When using Saf-T CI Vent double wall conduit sections proceed as above with the inner joint, sliding the outer sleeve out of the way. After the inner joint is secured and sealed, slide the two outer jackets to within 4 inches of each other and secure with the coupler, tightening the 3 screws evenly (figure 8 bottom). **NOTE.** When completed the inner sleeve of the Saf-T CI Vent will be able to move freely from the outer sleeve. This is to allow for the varying rates of thermal expansion in the system.

**DETAILED FREE-STANDING VERTICAL INSTALLATION**

1. Determine a safe and proper location for the roof penetration using the guidelines provided in the Pre-Installation Considerations above. It will be helpful to drill a small (1/4 inch) locator hole through all floor, ceiling and roof structures to verify the position of all penetrations. Make sure any electrical wiring or plumbing is not located in the area you will be opening. Once the proper location for the roof penetration is chosen enlarge the locator hole using a Saws-All or other method and frame around any structural openings (using proper and similar framing members) yielding an opening of at least 4" larger than the Saf-T Vent being installed. Install firestops on the top of framing members at each penetration of a floor or ceiling, clearing any insulating material for at least 4" from the outer surface of the Saf-T Vent sections. Position and install the Roof Jack Assembly per the instructions packed with the Roof Jack Assembly.

When extending more than 30 feet vertically and when the system is not terminating directly above the appliance flue collar (offsets or horizontal runs are incorporated in the system) vertical support kits are required once in every 30 feet of vertical run. Once all penetrations have been properly framed, flashed and firestopped and any required vertical support kits installed, the vent sections can be installed. Beginning with the appliance flue collar or flue adapter attach elbows and sections as required through the chosen path for the vent maintaining a continuous pitch toward the appliance of at least 1/4 inch per foot. If the horizontal portion of the vent connector is longer than 6 feet, install hanger straps (fabricated from non-combustible material) every 6 feet to support the connector from ceiling joists or other solid structures. **Note: Do not** rivet or screw the straps to the conduit or otherwise puncture the conduit wall. Instead, wrap an extra loop of strap around the conduit to hold it in position, or attach the strap to the couplers center screw of the double wall Saf-T CI Vent. While installing the vertical conduit install a vertical support kit after each transition to vertical and/or after every 30 feet of vertical conduit. The support bracket is to be securely attached to a wall or appropriate vertical member and positioned so that the support bracket will not infringe with any joints of the venting system. The bottom-most support bracket should be located directly above the first transition from horizontal to vertical run of over 30 feet. Subsequent vertical supports are required after every offset elbow or 30 feet of continuous vertical conduit. Refer to the vertical support instructions packed with the vertical support.

Once all penetrations of walls, ceilings, floors and roofs have been properly framed, flashed and firestops installed and all vertical supports are installed the vertical conduit can be installed. Care must be taken in the installation of vertical conduit that adequate support is maintained during the installation process. Depending on the particular support requirements of the system the vertical conduit can be installed from the top down or from the bottom up. When the only support of the system is from the roof jack structure then the installation must proceed from the top down, in all other cases it is recommended that the system be installed from the bottom up. An adjustable section is required between the highest vertical support and the roof support assembly. Refer to the detailed adjustable section instructions packed with the adjustable section.

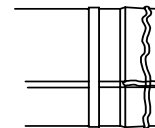
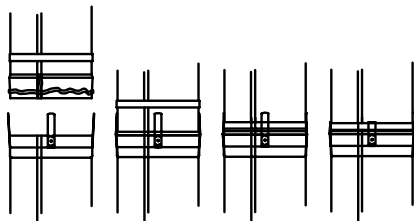

Figure 7.



1. apply sealant
2. fit sections
3. slide ring over tabs
4. bend tabs over ring

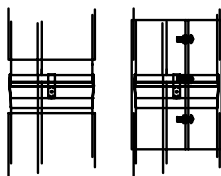

Figure 8.

8 or for large diameters see part V below). Again spread any extruded sealant around the joint. Finally, inspect the joint to ensure that flue gases will not escape. If necessary, apply additional sealant to any visible voids around the joint and smooth it into any crevices (pay special attention to any places that may have been damaged in shipping and handling). When using Saf-T CI Vent double wall conduit sections proceed as described above with the inner joint, sliding the outer sleeve out of the way. After the inner joint is secured and sealed, slide the two outer jackets to within 4 inch of each other and secure with the coupler, tightening the 3 screws evenly. NOTE. When completed the inner sleeve of the Saf-T CI Vent will be able to move freely from the outer sleeve. This is to allow for the

varying rates of thermal expansion in the system.

Continue with all additional sections until the conduit protrudes through the roof jack by at least 4 inches. **Allow the sealant to cure for 24 hours before operating the appliance.** Install the storm collar above the roof jack and finish the installation with a Saf-T CI Vent Rain Cap. The Rain Cap must **NOT** be sealed with RTV to allow for inspection of the system. If required by local codes or other indications the Saf-T CI Vent Raincap may be screened with the optional Saf-T Vent Rain Cap Screen Kit. If the system has other measures for eliminating rain water the Rain Cap may be omitted on positive pressure installations.

### DETAILED MASONRY CHIMNEY RELINING INSTALLATION

1. Follow the **Main Instructions** for Saf-T Vent Chimney Relining System packed with the single wall conduit sections to inspect and prepare the chimney. Locate the breaching hole and open the chimney as described in the **Main Instructions**. Before joining the elbow and conduit sections together, wipe the male and female ends clean with alcohol wipes. Apply a bead of GE RTV 106 sealant, about 1/4 inch in diameter,

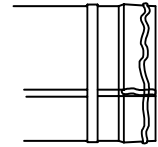

Figure 7.

completely around the **male** (without the tabs) end of each conduit section, between 1/4 and 3/8 inch from the end of the section. Also run a similar sized bead down the seam weld of each section, from the edge of the pipe to the top of the bulge (see Figure 7).

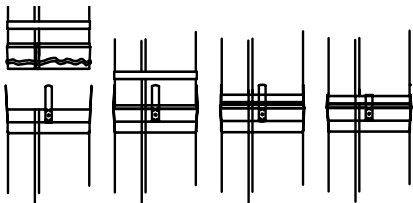

Figure 8.

Fully insert the male end of the section into the female fitting of the section below. With a moistened finger or flat tool, spread any sealant that squeezes out around the circumference of the joint. Attach the sections together with the locking ring and tabs as described in the general instructions (Figure 8). Again spread any extruded sealant around the joint. Finally, inspect the joint to ensure that flue gases will not escape. If necessary, apply additional sealant to any visible voids around the joint and smooth it into any crevices (pay special attention to any places that may have been damaged in shipping and handling). **Allow the sealant to cure for 24 hours before operating the appliance.**

2. Install the vertical flue gas conduit as described in sections D, E, F and G of the **Main Instructions**. With a 90°, 70° or 45° elbow installed at the base, attach a connector adapter to the elbow, as described in section H of the **Main Instructions**, using sealant at the joint as described above. Continue to attach sections of Saf-T Vent conduit and elbows, with the male ends toward the chimney, as necessary to connect the appliance to the vertical conduit. Be sure to seal **all** joints as described above.

Make sure that the vent connector slopes upward at least 1/4 inch per horizontal foot, and that proper clearance to combustibles is maintained. If the horizontal portion of the vent connector is longer than 6 feet, install hanger straps (fabricated from non-combustible material) every 6 feet to support the connector from ceiling joists or other solid structures. **Do not** rivet or screw the straps to the conduit or otherwise puncture the conduit wall. Instead, wrap an extra loop of strap around the conduit to hold it in position. When using double wall Saf-T CI Vent hanger straps may be attached to the center screw of the couplings. Alternatively a Heat-Fab, Inc. Saf-T Liner Top Support Clamp and Saf-T Vent Horizontal Support may be used see Saf-T Vent Connector Instructions packed with the Horizontal Support.

Make sure that the vent connector slopes upward at least 1/4 inch per horizontal foot, and that proper clearance to combustibles is maintained. If the horizontal portion of the vent connector is longer than 6 feet, install hanger straps (fabricated from non-combustible material) every 6 feet to support the connector from ceiling joists or other solid structures. **Do not** rivet or screw the straps to the conduit or otherwise puncture the conduit wall. Instead, wrap an extra loop of strap around the conduit to hold it in position. When using double wall Saf-T CI Vent hanger straps may be attached to the center screw of the couplings. Alternatively a Heat-Fab, Inc. Saf-T Liner Top Support Clamp and Saf-T Vent Horizontal Support may be used see Saf-T Vent Connector Instructions packed with the Horizontal Support.

### PART III CONNECTING THE APPLIANCE

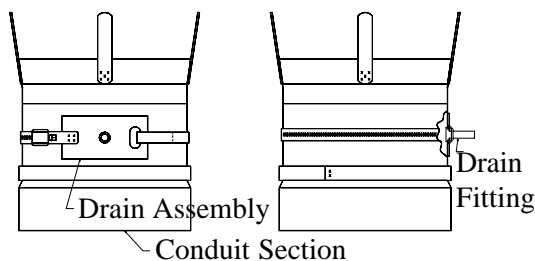

Figure 9.

**WARNING: NEVER INSTALL A DRAIN IN A SYSTEM WITH AN APPLIANCE NOT INVESTIGATED FOR USE WITH A CONDENSATE DRAIN.**

If the appliance instructions or local regulations call for a condensate drain installed in the vent conduit, and one is not provided by the appliance manufacturer, install a Saf-T Vent drain fitting in the horizontal conduit, as close as possible to the appliance flue collar. Locate the drain fitting so that the drain tube is as nearly vertical as possible. Apply a bead of RTV 106 sealant around the hole in the drain clamp assembly and clamp the Saf-T Vent drain fitting over the hole. Using a very sharp 1/4-inch drill make a 1/

4-inch hole in a the Saf-T Vent conduit using the drain tube as a drill guide. Place the flat head screw into the 1/4-inch hole with the washer and nut at the end of the drain tube. Tighten the nut until the screw is pulled flat with the inside surface of the conduit (figure 9). Remove the screw, nut and washer. Tighten the clamp strap being careful not to distort the conduit by over tightening. **Allow the sealant to cure for 24 hours before operating the appliance.**

If the connected appliance has a horizontal flue connector and a drain fitting is required a Saf-T Vent Tee or a Saf-T CI Vent Boot Tee with a drain fitting is strongly recommended. Use the straight tee for a straight horizontal run or the boot tee at a transition from horizontal to vertical. Attach the drain tee cover to the appropriate leg of the tee sealing the joint as above.

A trap loop must be formed into the drain hose and must be at least four times the appliance's rated stack pressure in inches of water column or 3 inches which ever is greater. Secure the loop with a cable tie (Figure 10). Prior to final assembly the trap loop must be 'primed' by pouring a small quantity of water into the drain hose. Attach the 3/8-inch

Figure 10

ID drain hose to the drain fitting and run the hose to a sanitary sewer drain maintaining the proper trap loop and following all local and national codes and regulations for the draining of acidic effluent.

Connect the Saf-T Vent system to the appliance flue collar as directed in the manufacturer's instructions. If required by local authorities, appliance manufacturers instructions or special conditions at the installation site provide a direct inlet for outside air to the appliance. Refer to appliance manufacturer recommendations for location and sizing of outside air inlets. If desired Saf-T Vent or Saf-T Liner may be used in ducting the outside air. The outside duct may be installed in the same chase as the Saf-T Vent Conduit provided the terminations are at least 4' apart. Refer to NFPA 54 for other recommendations on outside air ducting.

**Maintenance Instructions.**

Normal operation of gas burning appliances does not result in deposits of combustible soot in venting systems. However, a poorly adjusted or malfunctioning appliance can deposit soot, and other debris can enter the vent system. Just as with all vents the Saf-T Vent system should be inspected at least annually for the presence of deposits of soot or debris and any accumulation removed.

The system should also be inspected for signs of leakage of condensate or combustion products at any joints at regular periods. If any leakage is found the connected appliances should be turned off and the leaks must be repaired.

If the system incorporates a drain hose from either an inline fitting or from a drain tee the hose must be inspected periodically to assure that water is in the trap loop. If a proper trap loop is not maintained exhaust from the connected appliances may accumulate in the building area.

**Part V Connecting Large Diameter Saf-T CI Vent Conduit and Fittings**

In order to make connection of large diameter Saf-T CI Vent easier the 'Ring' is field assembled. Apply sealant to the male end of the conduit as described above. Wrap the Strap around the tabs of the assembled joint. Thread the end of the strap through the buckle and bend the strap back 180 degrees. Use pliers if necessary to assure the bend is located at the score line. Align the excess strap with a tab and bend tabs as previously described. The first tab will retain the excess strap on the 'Ring' (figure 11). Continue as described above with the coupling. The coupling will assist in retaining the excess strap in the correct position.

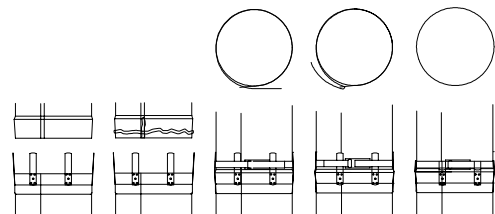

Figure 11



**TURNERS FALLS, MASSACHUSETTS**  
**(800) 772-0739**  
**www.heat-fab.com**  
 PUBLICATION # PI-CIINS R1102